



**WINDOW
PRODUCTS
LIMITED**

Tel: 01684 290944

Fax: 01684 276482

E: sales@gtwindowproducts.co.uk

www.gtwindowproducts.co.uk

STAY-GUARD

A simple, easy and effective method of enhancing security for windows.

The unique engineered shape and design of the Stay Guard Elite goes beyond meeting the industry's most demanding security standards.



- Available in various sizes to suit stack heights
- Can be used on PVCu, timber and aluminium
- Will assist in meeting PAS 24



STAY-GUARD

A simple, easy and effective method of enhancing security for windows.

The unique engineered shape and design of the Stay Guard Elite goes beyond meeting the industry's most demanding security standards.

This hinge protection device which, when fitted in conjunction with a friction stay, will assist in meeting the requirements of PAS 24.

Wherever possible and to obtain the best performance, the Stay Guard should be fitted into reinforcement.

Available in both 13mm and 17mm standard stack heights.

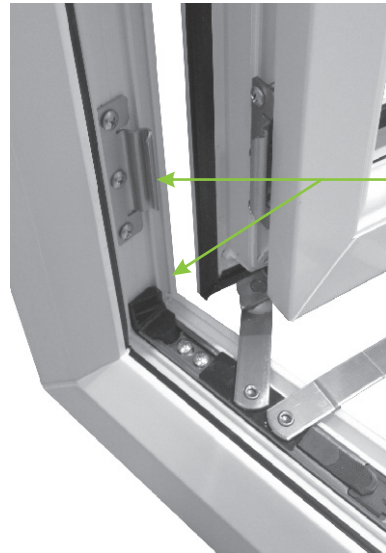

Fit the Stay Guards approx 75mm centres from the internal corner as shown here. Secure using 4.8 x 25 carbon steel zinc coated screws.

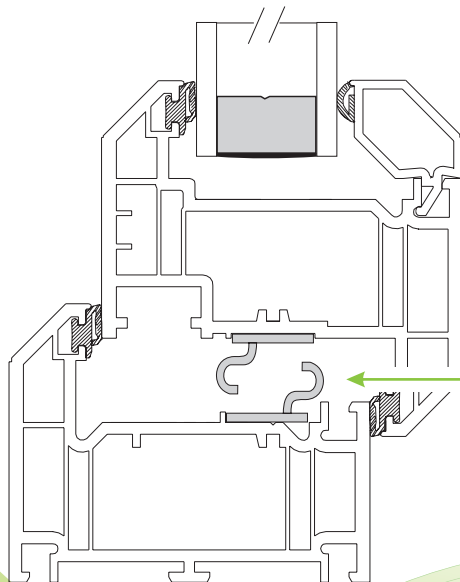

Typical positioning shown.

* Fit run up blocks on opposite side to the Stay Guard and pack the unit at the same positions to stop sash movement

Stay Guard Elite fitted to outer frame and sash for all types of stays including egress/easy clean

